

High-performance DC voltage current source/monitor capable of pulse source/measurement with a minimum pulse width of 50µs

New

- Wide ranging source/measurement
6241A Voltage: 0 to ± 32V Current: 0 to ± 500mA
6242 Voltage: 0 to ± 6V Current: 0 to ± 5A
- High source/measurement resolution
Source : 10µV/1nA Measurement : 1µV/100pA
- Basic source and measurement accuracy: ±0.02%
- Pulse measurement with a minimum pulse width of 50µs and 1µs step
- Two slope linear sweep function
- Sink-enabled bipolar output
- GPIB and USB interfaces

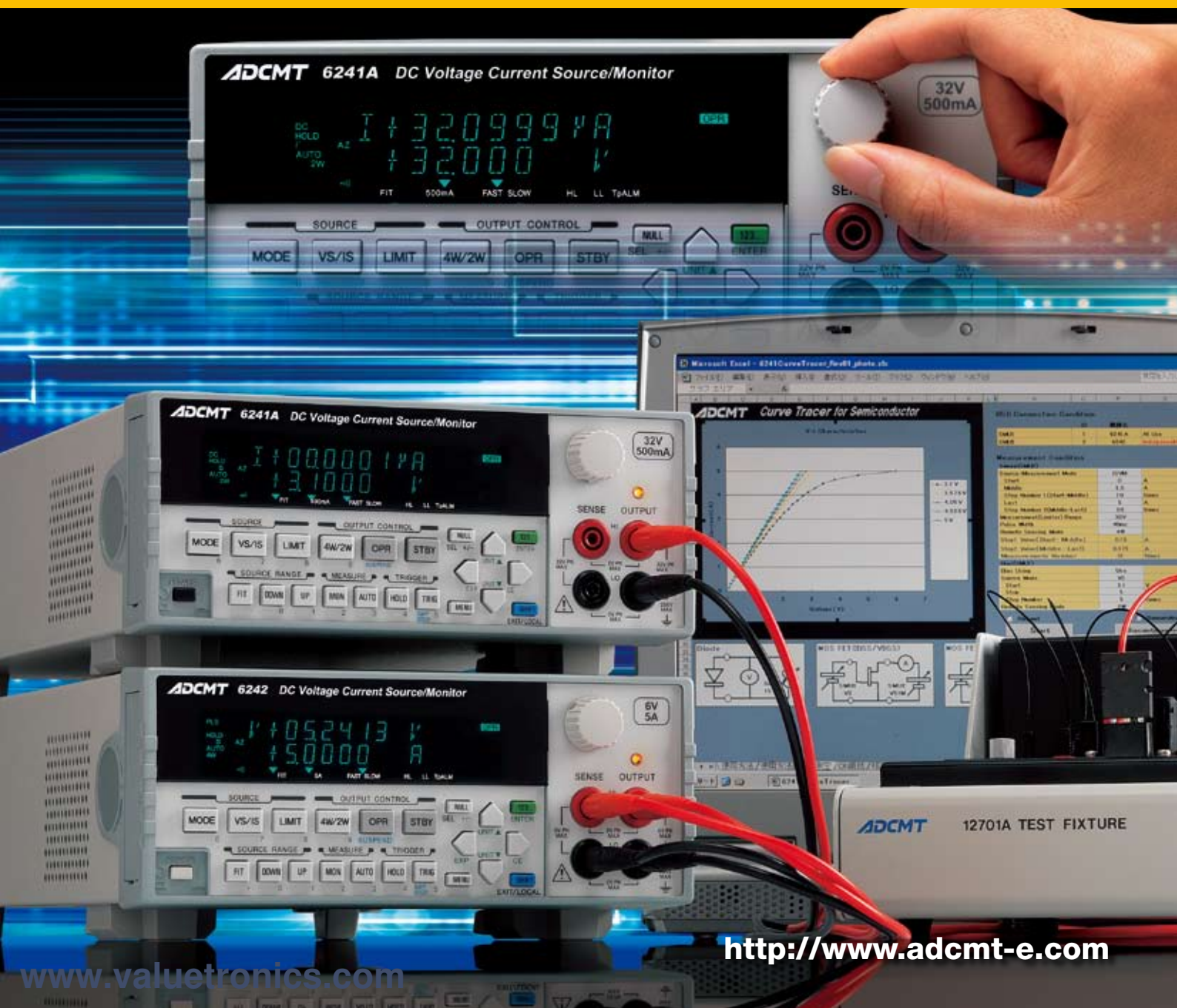

The 6241A/6242 is a DC voltage and current source/monitor capable of 4½-digit generation and 5½-digit measurement with high accuracy of ±0.02%.

The instrument has newly adopted a two slope linear sweep function in addition to conventional linear, fixed and random sweep functions, and is also capable of pulse measurement with a minimum pulse width of 50µs and low voltage/current measurement with a resolution of 1µV/100pA. Thus, it can be used for a wide range of applications as a power source for evaluation in research and development of semi-conductors and other electronic components, or for characteristic tests in a production line.

The sink-enabled bipolar output and the individual HI/LO limiter function are effective in evaluation of batteries and power ICs. Moreover, the new suspend function enables selection of the optimum OFF state for each application, contributing to the throughput improvement.

GPIB and USB interfaces are mounted as standard.

Voltage/Current Source Mode

There are four source modes; DC, pulse, DC sweep, pulse sweep. Then, the sweep modes are classified into four sweep types: fixed sweep, linear sweep, random sweep (user programmable sweep), two slope linear sweep (linear sweep with step value switching). The minimum pulse width is 50µs.

The minimum cycle is 2ms, or 500µs without measurement.

	DC	PULSE
Continuous spot		
Fixed sweep		
Linear sweep		
Random sweep		
Two slop linear slope		

The new sweep function offers a wider range of applications

Two slope linear sweep



GPIB

USB

Source/Measurement Function

Voltage/current source and voltage/current/resistance measurement can be selected by specifying the source and measurement functions.

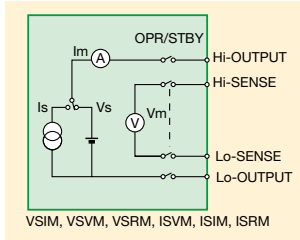

Output Range

- 6241A Voltage: 0 to $\pm 32V$
Current: 0 to $\pm 500mA$
- 6242 Voltage: 0 to $\pm 6V$
Current: 0 to $\pm 5A$

6241A
6242

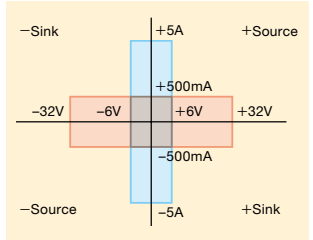

Individual Settings of HI/LO Limiters

In voltage/current source, the HI/LO limiter settings are very important. For current source, the limiter voltage must be higher than the applied voltage. When voltage higher than the limiter voltage is applied from the outside, the instrument detects overload and sets standby. When a capacitor is discharged after being charged at a constant current with the positive and negative limiters being set to the same value, overload occurs if the limiter voltage is lowered. In addition, it is discharged down to negative voltage when applying reverse polarity current.

However, the 6241A/6242 has a function that can set the HI and LO limiters individually. Furthermore, for the voltage-limiter, both HI and LO limiters can be set homo-polar. This prevents a capacitor or a battery from being over-discharged. Also, it is suitable for evaluating devices such as LDs that are used at a constant current and do not tolerate reverse voltage application.

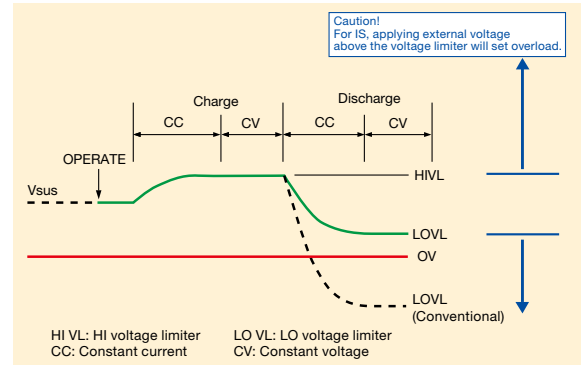

Suspend Function

The 6241A/6242 can select from three output OFF statuses; STBY (output relay OFF), HiZ (output relay ON and high resistance), and LoZ (output relay ON and low resistance). Using this function can omit unnecessary relay ON/OFF action, which reduces deterioration of the throughput due to relay operation time and improves the life span of the relay. In addition, the setting of a suspend voltage (voltage in HiZ and LoZ status) prevents transient current sink that occurs at a connection of a voltage output device such as a battery.

When a conventional generator or electronic load is connected with a battery, the output voltage is 0V, and then the setting current starts flowing. In this case, the moment that it is connected, transient current sink occurs, causing unnecessary battery discharge.

On the other hand, by setting a suspend voltage, the 6241A/6242 is connected in high-impedance state at the specified voltage and then the setting current flows. This prevents unnecessary discharge at the connection to a battery.

For the 6241A/6242, the source modes can be switched in such suspend status, which reduces deterioration of the throughput due to source mode switching.

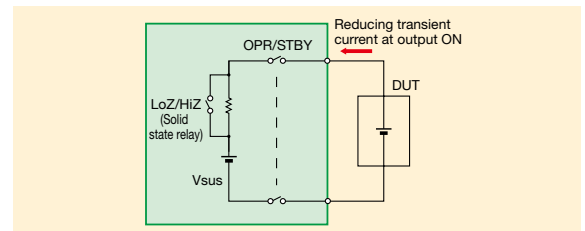

Output OFF status	Output relay	Output status	Current-limiter setting value
LoZ	ON	Vsus, low resistance	VS: Set current limiter (IL) IS: 1/1000 of the current setting range
HiZ	ON	Vsus, high resistance	30 μA
STBY	OFF	Open	-

Vsus: Setting suspend voltage (default: 0V)

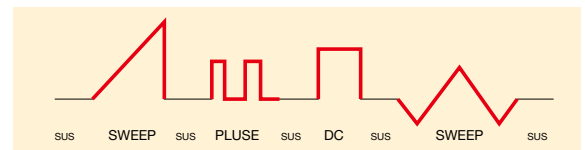

High-Speed Response and Low Noise

The typical waveform and output noise of the 6241A/6242 are shown below.

The response of 0-3V is approximately 8.5 μs at 0-90% rising time, and the output noise is approximately 2.2mVp-p at DC-20MHz.

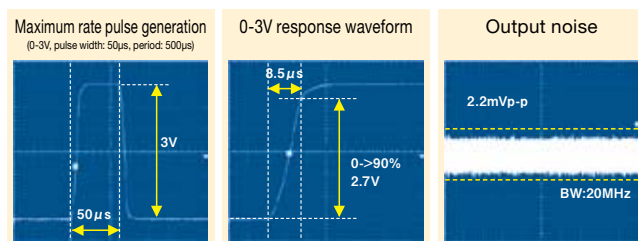

Sample Hold Measurement

Sample hold measurement is available in the pulse mode and the pulse sweep mode. Measurement holds an input signal immediately before pulse falling edge, and A/D conversion is implemented for integration time of 100 μs .

In this case, the setting measurement delay time is ignored.

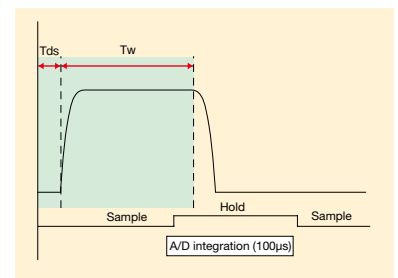

Applications

For Battery Charge/Discharge Tests and Power Device Evaluation

The 6241A/6242 handles bipolar output and is capable of \pm source and \pm sink operations. Therefore, it has achieved 0V sink operation which cannot be done by a general electronic load. With its pulse source function, it can be used for evaluation of batteries and power supply devices used for various portable devices.

- Capable of handling pulses of cellular phones with a minimum pulse width of 50 μ s and 1 μ s step.
- Capable of CV/CC operation for both charging and discharging by using HI/LO voltage limiters.

Both HI and LO voltage limiters can be set to + value (or - value). If HI is set to +1.8V and LO to +1.2V, for instance, the mode becomes constant voltage operation when the battery voltage reaches +1.8V, and discharging terminates when it reaches +1.2V.

- Avoids unnecessary discharge at output ON by setting a suspend voltage (V_{sus}).

A general power supply is at 0V or in open status of 0V when output is OFF, and a low impedance state of 0V always occurs when output is ON. At this time, the battery is being discharged unnecessarily for a moment. However, by setting the suspend voltage of the 6241A/6242 to +1.2V, for instance, unnecessary discharge can be avoided since the voltage of the output terminal is +1.2V the same as that of the battery, even in a temporary low impedance state that occurs when the output is ON. This function is also useful for preventing FET from being set to ON instantaneously at output ON when it is used as a gate voltage of J-FET or GaAsFET.

Connection Diagram

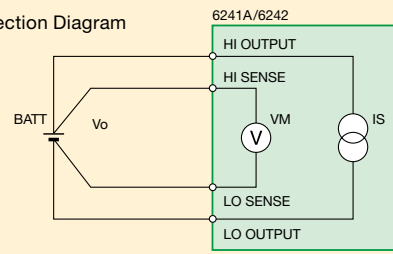

Pulse Discharge Waveform

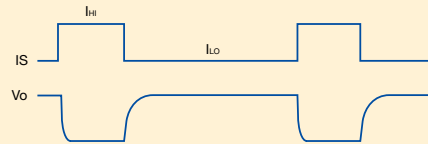

Battery Charge Waveform

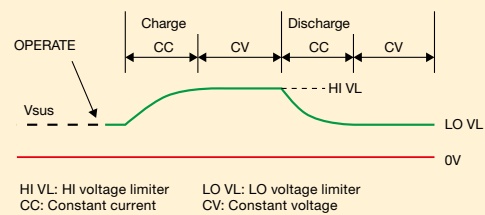

For Evaluation of Solar Cells

Since the conversion efficiency of a solar cell is influenced by bias application time, measurement by pulse application is effective in finding the true conversion efficiency. By using the pulse sweep function of the 6241A/6242, the I-V curve can be measured at high speed. Furthermore, by changing the pulse width, the change in characteristics depending on the application time can be measured easily. In addition, the two slope linear sweep function that can switch the step value during measurement enables measurement from the vicinity of voltage at the peak power point to open-circuit voltage in small steps.

- Pulse measurement with a minimum pulse width of 50 μ s and a minimum period of 2ms
- Minimum voltage step: 10 μ V (300mV range)
- Two slope linear sweep
Sweeps by Step1 between First and Middle
Sweeps by Step2 between Middle and Last

Connection Diagram

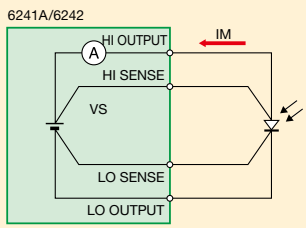

Measurement Waveform

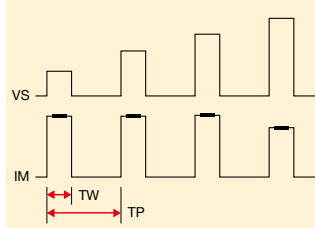

Light I-V Characteristics

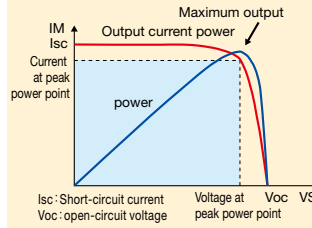

Two Slope Linear Sweep Example

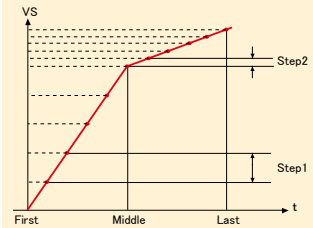

USB Interface as Standard

This instrument can easily capture measurement data by connecting to a PC through a USB interface installed as standard in addition to a GPIB interface. USB driver is available from our website.



For ON-Resistance Measurement of MOSFET and Analog Switch

The following shows an example of ON-resistance measurement of MOSFET. The drain side is a 4-wire ISVM circuit. The current at ON state is determined by the source current (IS), and the drain voltage at OFF state is determined by the voltage limiter (VL). The gate side inputs the SYNC OUT signal to TRIGGER IN of the 6242 on the drain side as pulse source of VSIM. In this way, synchronous measurement by two units is achieved. The results of ON-resistance measurement can be displayed in ohms. In addition, by using the linear pulse sweep function on the gate side and the fixed sweep function on the drain side, gate voltage - ON resistance characteristics can be measured easily.

- Resistance measurement range:
6241A 2μΩ to 1.6GΩ
6242 0.2μΩ to 304MΩ
- Maximum current (IdMax): 6241A 500mA
6242 5A
- Pulse measurement with a minimum pulse width of 50μs and a minimum period of 2ms
- Gate current measurement with a resolution of 100pA
The specifications of synchronous measurement are compatible with those of the 6240A.

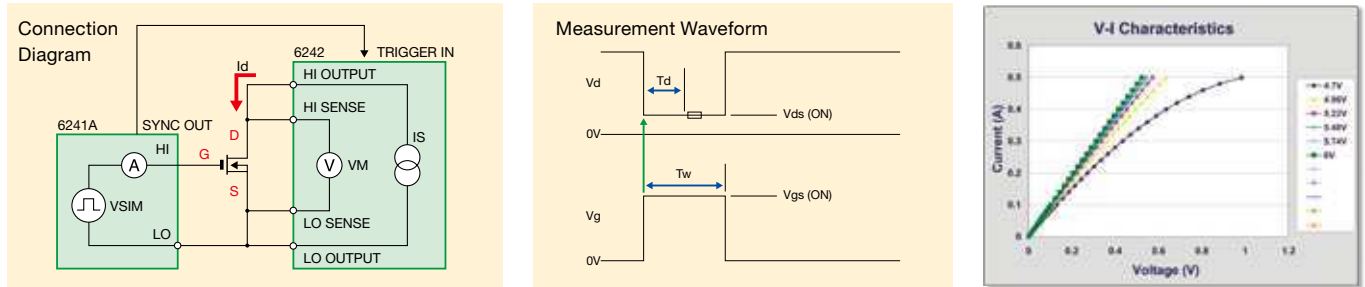

For DC Characteristic Evaluation of Transistor and FET

The following shows an example of transistor DC characteristic measurement using two units. In order to perform measurement by two units of the 6241A/6242 in synchronization, SYNC OUT of one unit on the base current (Ib) side is connected to TRIGGER IN of the other unit on the collector (Vce) side. In Vce-Ic characteristic measurement, the collector current (Ic) is measured by sweeping the collector-emitter voltage (Vce) of one unit with the base current (Ib) on the other unit remaining constant. In Ib-Ic characteristic measurement, by sweeping the base current (Ib) on one unit, the collector current (Ic) is measured by the other synchronized unit.

- DC/pulse sweep function
- Maximum setting range: ± 32V/± 500mA (6241A), ± 6V/± 5A (6242)
- Measurement resolution: 1μV/100pA
- Pulse measurement with a minimum pulse width of 50μs and a minimum period of 2ms
- Synchronous operation

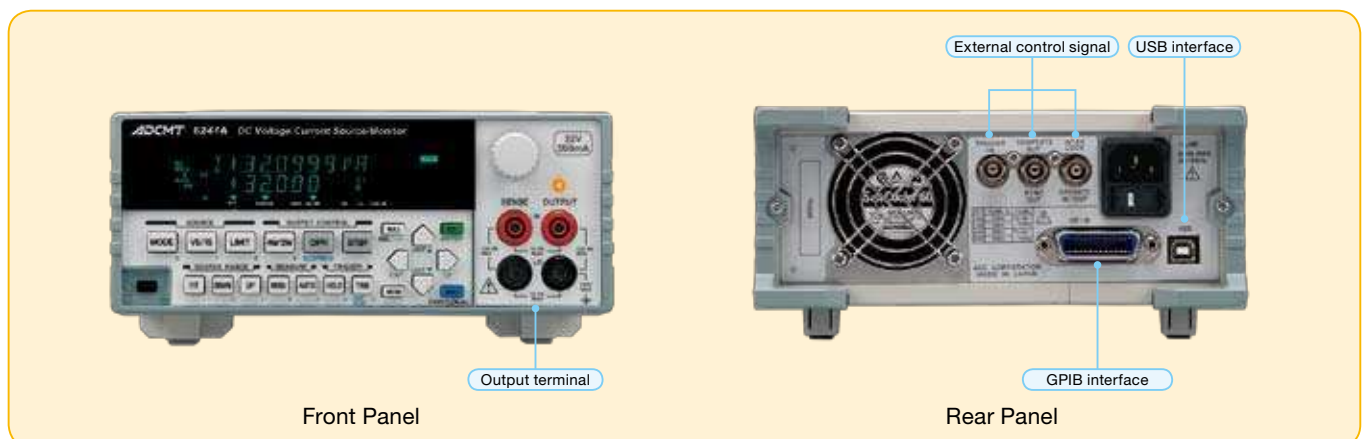
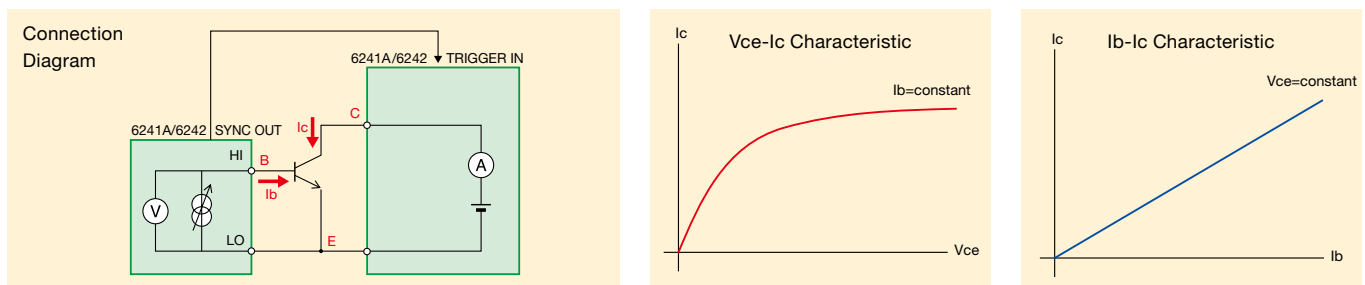

Specifications

All accuracy specifications are guaranteed for one year at a temperature of $23 \pm 5^\circ\text{C}$ and a relative humidity of 85% or less.

6241A

Voltage source/measurement range:

Range	Source range	Setting resolution	Measurement range	Measurement resolution
300mV	0 to $\pm 320.00\text{mV}$	10 μV	0 to $\pm 320.999\text{mV}$	1 μV
3V	0 to $\pm 3.2000\text{V}$	100 μV	0 to $\pm 3.20999\text{V}$	10 μV
30V	0 to $\pm 32.000\text{V}$	1mV	0 to $\pm 32.0999\text{V}$	100 μV

Current source/measurement range:

Range	Source range	Setting resolution	Measurement range	Measurement resolution
30 μA	0 to $\pm 32.000\mu\text{A}$	1nA	0 to $\pm 32.0999\mu\text{A}$	100pA
300 μA	0 to $\pm 320.00\mu\text{A}$	10nA	0 to $\pm 320.999\mu\text{A}$	1nA
3mA	0 to $\pm 3.2000\text{mA}$	100nA	0 to $\pm 3.20999\text{mA}$	10nA
30mA	0 to $\pm 32.000\text{mA}$	1 μA	0 to $\pm 32.0999\text{mA}$	100nA
300mA	0 to $\pm 320.00\text{mA}$	10 μA	0 to $\pm 320.999\text{mA}$	1 μA
500mA	0 to $\pm 500.00\text{mA}$	20 μA	0 to $\pm 500.999\text{mA}$	1 μA

However, the measurement resolution with integration time 100 μs , 500 μs and S/H (Sample Hold) will be as follows:

Integration time	100 μs	500 μs	S/H (100 μs)
Measurement resolution (digits)	10	2	10

Resistance measurement range:

Range	Measurement range	Measurement resolution
Determined by voltage range and current range calculations	0 Ω to 1.6G Ω	Minimum 2 $\mu\Omega$

Voltage limiter (compliance) range:

Setting range	Setting resolution*1
0V to 320mV	100 μV
320.1mV to 3.2V	1mV
3.201V to 32V	10mV

Current limiter (compliance) range:

Setting range	Setting resolution*1
100nA to 32 μA	10nA
32.01 μA to 320 μA	100nA
320.1 μA to 3.2mA	1 μA
3.201mA to 32mA	10 μA
32.01mA to 320mA	100 μA
320.1mA to 500mA	100 μA

*1: Where, (Hi limiter value - Lo limiter value) \geq 60 digits

Overall accuracy: Includes calibration accuracy, 1-day stability, temperature coefficient and linearity

1-day stability: Under constant power and load

Temperature coefficient: At temperature of 0 to 50 $^\circ\text{C}$

Voltage source:

Range	Overall accuracy	1-day stability	Temperature coefficient
	\pm (% of setting+V)		\pm (ppm of setting+V)/ $^\circ\text{C}$
300mV	0.02+150 μV	0.01+70 μV	15+15 μV
3V	0.02+350 μV	0.01+200 μV	15+30 μV
30V	0.02+3mV ^{*2}	0.01+2mV	15+300 μV

*2: In the 30V range, 200 μV is added per remote sense voltage 0.1V

Voltage limiter:

Range	Overall accuracy	1-day stability	Temperature coefficient
	\pm (% of setting+V)		\pm (ppm of setting+V)/ $^\circ\text{C}$
300mV	0.1+500 μV	0.05+200 μV	100+50 μV
3V	0.05+3mV	0.01+1mV	15+100 μV
30V	0.05+30mV	0.01+10mV	15+1mV

Voltage limiter additional error: When Hi limiter is set to a negative value and Lo limiter is set to a positive value, an error of $\pm 0.1\%$ of setting is added.

Current source:

Range	Overall accuracy	1-day stability	Temperature coefficient
	\pm (% of setting+A+A \times Vo/1V)		\pm (ppm of setting+A+A \times Vo/1V)/ $^\circ\text{C}$
30 μA	0.03+10nA+300pA	0.01+5nA+100pA	20+1nA+10pA
300 μA	0.03+80nA+3nA	0.01+40nA+1nA	20+10nA+100pA
3mA	0.03+800nA+30nA	0.01+400nA+10nA	20+100nA+1nA
30mA	0.03+8 μA +300nA	0.01+4 μA +100nA	20+1 μA +10nA
300mA	0.045+80 μA +3 μA	0.01+40 μA +1 μA	20+10 μA +100nA
500mA	0.05+160 μA +6 μA	0.02+80 μA +1 μA	20+12 μA +200nA

Current limiter:

Range	Overall accuracy	1-day stability	Temperature coefficient
	\pm (% of setting+A+A \times Vo/1V)		\pm ppm of setting+A+A \times Vo/1V/ $^\circ\text{C}$
30 μA	0.045+35nA+300pA	0.01+10nA+100pA	20+8nA+10pA
300 μA	0.045+350nA+3nA	0.01+100nA+1nA	20+20nA+100pA
3mA	0.045+3.5 μA +30nA	0.01+1 μA +10nA	20+200nA+1nA
30mA	0.045+35 μA +300nA	0.01+10 μA +100nA	20+2 μA +10nA
300mA	0.055+350 μA +3 μA	0.01+100 μA +1 μA	20+20 μA +100nA
500mA	0.055+500 μA +6 μA	0.02+100 μA +1 μA	40+20 μA +200nA

Vo: Compliance voltage (-32V to +32V)

Voltage measurement: (Auto zero: ON, integration time: 1PLC to 200ms)

Range	Overall accuracy	1-day stability	Temperature coefficient
	\pm (% of reading+V)		\pm (ppm of reading+V)/ $^\circ\text{C}$
300mV	0.02+75 μV	0.008+50 μV	15+15 μV
3V	0.02+120 μV	0.008+60 μV	15+15 μV
30V	0.02+1.2mV ^{*2}	0.008+400 μV	15+150 μV

*2: In the 30V range, 200 μV is added per remote sense voltage 0.1V.

Current measurement: (Auto zero: ON, integration time: 1PLC to 200ms)

Range	Overall accuracy	1-day stability	Temperature coefficient
	\pm (% of reading+A+A \times Vo/1V)		\pm (ppm of reading+A+A \times Vo/1V)/ $^\circ\text{C}$
30 μA	0.03+8nA+300pA	0.01+4nA+100pA	20+1nA+10pA
300 μA	0.03+70nA+3nA	0.01+35nA+1nA	20+7nA+100pA
3mA	0.03+700nA+30nA	0.01+350nA+10nA	20+70nA+1nA
30mA	0.03+7 μA +300nA	0.01+3.5 μA +100nA	20+700nA+10nA
300mA	0.045+70 μA +3 μA	0.01+35 μA +1 μA	20+7 μA +100nA
500mA	0.05+120 μA +6 μA	0.02+60 μA +1 μA	35+10 μA +200nA

Resistance measurement: (Auto zero: ON, integration time: 1PLC to 200ms)

Condition	Overall accuracy	1-day stability	Temperature coefficient
	\pm (% of reading) \pm (digits+digits+digits)		\pm (ppm of reading) \pm (digits+digits+digits)/ $^\circ\text{C}$
At voltage source	Reading item: (Voltage source setting item + Current measurement reading item) Full-scale item: (Voltage source full-scale item digit value + current measurement full-scale item digit value + CMV item digit value) ^{*3}		
At current source	Reading item: (Current source setting item + Voltage measurement reading item) Full-scale item: (Current source full-scale item digit value + Voltage measurement full-scale item digit value + CMV item digit value) ^{*3}		

Vo: Compliance voltage (-32V to +32V)

*3: CMV item = (A \times Vo/1V); source or measurement current \times source or measurement voltage/1V digit value

The full-scale item tolerances listed below are added to the integration time 100 μs to 10 ms measurement accuracy and 1-day stability.

Measurement range	Integration time						Unit : digits (at 5 1/2 digit display)
	10ms	5ms	1ms	500 μs	100 μs	S/H	
Voltage measurement	300mV	10	15	20	30	60	200
	3V, 30V	5	8	10	15	30	50
	30 μA	200	300	300	300	300	300
Current measurement	300 μA	20	30	30	30	70	100
	3mA	10	30	30	30	50	80
	30mA	10	30	30	30	50	100
	300mA	10	15	15	15	50	100
	500mA	10	30	30	30	50	200

S/H: Measurement in the sample hold mode (integration time: 100 μs)

When LO OUTPUT is grounded to the chassis, the additional error of integration time in the 30 μA range is the same as that in the 300 μA range.

Source linearity: ± 3 digits or less
(In the 500mA range, ± 5 digits or less)

Maximum output current: 0 to 32V; $\pm 500\text{mA}$
(Maximum pulse width: 20ms, duty factor: 20% or less)

Maximum compliance voltage: Up to 500mA: 0 to $\pm 32\text{V}$

6242

Voltage source/measurement range:

Range	Source range	Setting resolution	Measurement range	Measurement resolution
300mV	0 to ±320.00mV	10µV	0 to ±320.999mV	1µV
3V	0 to ±3.2000V	100µV	0 to ±3.20999V	10µV
6V	0 to ±6.000V	1mV	0 to ±6.0999V	100µV

Current source/measurement range:

Range	Source range	Setting resolution	Measurement range	Measurement resolution
30µA	0 to ±32.000µA	1nA	0 to ±32.0999µA	100pA
300µA	0 to ±320.00µA	10nA	0 to ±320.999µA	1nA
3mA	0 to ±3.2000mA	100nA	0 to ±3.20999mA	10nA
30mA	0 to ±32.000mA	1µA	0 to ±32.0999mA	100nA
300mA	0 to ±320.00mA	10µA	0 to ±320.999mA	1µA
3A	0 to ±3.0000A	100µA	0 to ±3.00999A	10µA
5A	0 to ±5.0000A	200µA	0 to ±5.00999A	10µA

However, the measurement resolution with integration time 100µs, 500µs and S/H (Sample Hold) will be as follows:

Integration time	100µs	500µs	S/H(100µs)
Measurement resolution (digits)	10	2	10

Resistance measurement range:

Range	Measurement range	Measurement resolution
Determined by voltage range and current range calculations	0Ω to 304MΩ	Minimum 0.2µΩ

Voltage limiter (compliance) range :

Setting range	Setting resolution ^{*1}
0V to 320mV	100µV
320.1mV to 3.2V	1mV
3.201V to 6V	10mV

Current limiter (compliance) range :

Setting range	Setting resolution ^{*1}
100nA to 32µA	10nA
32.01µA to 320µA	100nA
320.1µA to 3.2mA	1µA
3.201mA to 32mA	10µA
32.01mA to 320mA	100µA
320.1mA to 3A	1mA
3.001A to 5A	1mA

*1: Where, (Hi limiter value – Lo limiter value) ≥ 60 digits

Overall accuracy: Includes calibration accuracy, 1-day stability, temperature coefficient and linearity

1-day stability: Under constant power and load

Temperature coefficient: At temperature of 0 to 50°C

Voltage source:

Range	Overall accuracy	1-day stability	Temperature coefficient
	±(% of setting+V)		±(ppm of setting+V)/°C
300mV	0.02+150µV	0.01+70µV	15+15µV
3V	0.02+350µV	0.01+200µV	15+30µV
6V	0.025+3mV ^{*2}	0.01+2mV	15+300µV

*2: In the 6V range, 200µV is added per remote sense voltage 0.1V.

Voltage limiter:

Range	Overall accuracy	1-day stability	Temperature coefficient
	±(% of setting+V)		±(ppm of setting+V)/°C
300mV	0.1+500µV	0.05+200µV	100+50µV
3V	0.05+3mV	0.01+1mV	15+100µV
6V	0.16+30mV	0.018+10mV	36+1mV

Voltage limiter additional error: When Hi limiter is set to a negative value and Lo limiter is set to a positive value, an error of ±0.1% of setting is added.

Current source:

Range	Overall accuracy	1-day stability	Temperature coefficient
	±(% of setting+A+A×Vo/1V)		±(ppm of setting+A+A×Vo/1V)/°C
30µA	0.03+10nA+300pA	0.01+5nA+100pA	20+1nA+10pA
300µA	0.03+80nA+3nA	0.01+40nA+1nA	20+10nA+100pA
3mA	0.03+800nA+30nA	0.01+400nA+10nA	20+100nA+1nA
30mA	0.03+8µA+300nA	0.01+4µA+100nA	20+1µA+10nA
300mA	0.045+80µA+3µA	0.01+40µA+1µA	20+10µA+100nA
3A	0.08+2.5mA+150µA	0.06+1.5mA+25µA	50+300µA+20µA
5A	0.15+2.5mA+150µA	0.12+1.5mA+25µA	50+300µA+20µA

Current limiter:

Range	Overall accuracy	1-day stability	Temperature coefficient
	±(% of setting+A+A×Vo/1V)		±(ppm of setting+A+A×Vo/1V)/°C
30µA	0.045+35nA+300pA	0.01+10nA+100pA	20+8nA+10pA
300µA	0.045+350nA+3nA	0.01+100nA+1nA	20+20nA+100pA
3mA	0.045+3.5µA+30nA	0.01+1µA+10nA	20+200nA+1nA
30mA	0.045+35µA+300nA	0.01+10µA+100nA	20+2µA+10nA
300mA	0.055+350µA+3µA	0.01+100µA+1µA	20+20µA+100nA
3A	0.1+4mA+150µA	0.06+2mA+25µA	80+500µA+20µA
5A	0.15+4mA+150µA	0.12+2mA+25µA	80+500µA+20µA

Vo: Compliance voltage (-6V to +6V)

Voltage measurement: (Auto zero: ON, integration time: 1PLC to 200ms)

Range	Overall accuracy	1-day stability	Temperature coefficient
	±(% of reading+V)		±(ppm of reading+V)/°C
300mV	0.02+75µV	0.008+50µV	15+15µV
3V	0.02+120µV	0.008+60µV	15+15µV
6V	0.02+1.2mV ^{*2}	0.008+600µV	15+150µV

*2: In the 6V range, 200µV is added per remote sense voltage 0.1V.

Current measurement: (Auto zero: ON, integration time: 1PLC to 200ms)

Range	Overall accuracy	1-day stability	Temperature coefficient
	±(% of reading+A+A×Vo/1V)		±(ppm of reading+A+A×Vo/1V)/°C
30µA	0.03+8nA+300pA	0.01+4nA+100pA	20+1nA+10pA
300µA	0.03+70nA+3nA	0.01+35nA+1nA	20+7nA+100pA
3mA	0.03+700nA+30nA	0.01+350nA+10nA	20+70nA+1nA
30mA	0.03+7µA+300nA	0.01+3.5µA+100nA	20+700nA+10nA
300mA	0.045+70µA+3µA	0.01+35µA+1µA	20+7µA+100nA
3A	0.08+2.2mA+150µA	0.05+1.5mA+25µA	50+300µA+20µA
5A	0.15+2.2mA+150µA	0.12+1.5mA+25µA	50+300µA+20µA

Resistance measurement: (Auto zero: ON, integration time: 1PLC to 200ms)

Condition	Overall accuracy	1-day stability	Temperature coefficient
	±(% of reading) ±(digits+digits+digits)		±(ppm of reading) ±(digits+digits+digits)/°C
At voltage source	Reading item: (Voltage source setting item + Current measurement reading item) Full-scale item: (Voltage source full-scale item digit value + current measurement full-scale item digit value + CMV item digit value) ^{*3}		
At current source	Reading item: (Current source setting item + Voltage measurement reading item) Full-scale item: (Current source full-scale item digit value + Voltage measurement full-scale item digit value + CMV item digit value) ^{*3}		

Vo: Compliance voltage (-6V to +6V)

*3: CMV item = (A × Vo/1V); source or measurement current × source or measurement voltage/1V digit value

The full-scale item tolerances listed below are added to the integration time 100µs to 10 ms measurement accuracy and 1-day stability.

Measurement range	Integration time Unit: digits (at 5 ½ digit display)					
	10ms	5ms	1ms	500µs	100µs	S/H
Voltage measurement	300mV	10	15	20	30	200
	3V, 6V	5	8	10	15	50
Current measurement	30µA	200	300	300	300	300
	300µA	20	30	30	30	100
	3mA	10	30	30	30	80
	30mA	10	30	30	30	100
	300mA	10	15	15	15	100
	3A	20	30	75	75	500
5A	20	30	75	75	500	

S/H: Measurement in the sample hold mode (integration time: 100µs)

When LO OUTPUT is grounded to the chassis, the additional error of integration time in the 30µA range is the same as that in the 300µA range.

Source linearity: ±3 digits or less
(In the 5A range, ±5digits or less)

Maximum output current: 0 to 6V; ±5A
(Maximum pulse width: 20ms, duty factor: 20% or less)

Maximum compliance voltage: Up to 5A: 0 to ±6V

6241A/6242

6241A/6242 range list

	Range	6241A	6242
Voltage source/ voltage limiter	300mV	✓	✓
	3V	✓	✓
	6V	—	✓
	30V	✓	—
Current source/ current limiter	30µA	✓	✓
	300µA	✓	✓
	3mA	✓	✓
	30mA	✓	✓
	300mA	✓	✓
	500mA	✓	—
	3A	—	✓
5A	—	✓	

Output noise: For voltage source, within the range from no load to the maximum load [Vp-p]

For current source, at the following load [Ap-p]

Voltage source:

Range	Load resistance	Low frequency noise		High frequency noise
		DC to 100kHz	DC to 10kHz	DC to 20MHz
300mV	—	50µV	200µV	3mV
3V	—	50µV	300µV	3mV
30V/6V	—	500µV	2mV	4mV

Current source:

Range	Load resistance	Low frequency noise		High frequency noise
		DC to 100kHz	DC to 10kHz	DC to 20MHz
30µA	10kΩ	10nA	60nA	500nA
300µA	10kΩ	30nA	150nA	600nA
3mA	1kΩ	200nA	2µA	6µA
30mA	1kΩ	2µA	15µA	20µA
300mA	1kΩ	20µA	100µA	150µA
500mA	1kΩ	20µA	100µA	150µA
3A	10Ω	500µA	1mA	10mA
5A	10Ω	500µA	1mA	10mA

Switching noise:

		Typical value [p-p]	Load resistance
Output ON/OFF noise	Voltage source	600mV	At 100kΩ
	Current source	600mV	At 100kΩ
Range switching noise	Voltage source	50mV	—
	Current source	fast: 100digits+50mV ^{*4}	—
	Current limiter	slow: 300digits+50mV ^{*4}	—
	Voltage limiter	50mV ^{*5}	—
	Voltage measurement	50mV ^{*5}	—
Response switching noise		80mV	
Power OFF noise		600mV	At 100kΩ

*4: "digits" indicates current source 4½ digit values. Double these values in the 500mA range.
In the 3A and 5A ranges, fast: 300 digits + 50mV, slow: 600digits + 50mV

*5: The Limiter is inactive. While the limiter is active, it is the same as the current source range switching noise.

Settling time :

Time to reach the final value ±0.1% when varying the output from zero to full-scale

Setting condition: Source values and limiter values are full-scale settings.

Load conditions: Resistive load and 200pF max. load capacitance.

	Source range	Limiter range	Settling time		
			Output response		
			FAST	SLOW	
Voltage source Output current: 6241A: 500mA 6242: 5A	300mV	500mA/5A	200µs/300µs or less	1ms or less	
	3V		70µs/200µs or less	400µs/500µs or less	
	6V	5A	400µs or less	800µs or less	
	30V	500mA	300µs or less	1.5ms or less	
Current source Output voltage: 6241A: 30V 6242: 6V	30µA	30V/6V	2ms or less	3.5ms/3ms or less	
	300µA		600µs/200µs or less	2.5ms/600µs or less	
	3mA				
	30mA	30V	700µs or less	3ms or less	
	300mA		6V	700µs or less	1.5ms or less
	500mA				
	3A				
5A					

(Typical value)	Source range	Limiter range	Settling time	
			Output response	
			FAST	SLOW
Voltage source Output current: with less than 20% of full scale load	300mV	3mA~300mA	35µs or less	300µs or less
	3V		30µs or less	200µs or less
	30V/6V		100µs/40µs or less	500µs/300µs or less
Current source Output voltage: 1V	30µA	3V	800µs or less	1ms or less
	300µA		30µs or less	200µs or less
	3mA			
	30mA	50µs or less	250µs or less	
	300mA			
	500mA			
	3A	100µs or less	300µs or less	
5A				

Over shoot: ±0.1% or less under resistive load and at the standard cable end (30µA, 300µA, 3A and 5A ranges excluded)

Line regulation: ±0.003% of range or less

Load regulation:

Voltage source: ±0.003% of range or less (at 4-wire connection under the maximum load)

Current source: Depending on the overall accuracy CMV (A × Vo/1V)

Output resistance: At 2-wire connection (Output cable not included)

Maximum load capacitance: Maximum load capacitance that does not generate oscillation in voltage source or voltage limiter status

Range	Output resistance		Maximum load capacitance
	Voltage source	Current source	
30µA	500mΩ or less	1000MΩ or higher	1µF
300µA	100mΩ or less	1000MΩ or higher	1µF
3mA	10mΩ or less	100MΩ or higher	100µF
30mA	10mΩ or less	10MΩ or higher	100µF
300mA/500mA	10mΩ or less	1MΩ or higher	2000µF
3A/5A	10mΩ or less	70kΩ or higher	2000µF

Maximum inductive load: Maximum inductive load that does not generate oscillation in current source or voltage limiter status

Current source range/current limiter range	Response	30µA	300µA	3mA to 5A
		FAST	100µH	200µH
Maximum inductive load	SLOW	500µH		1mH

Effective CMRR: At unbalanced impedance 1kΩ
In DC and AC 50/60 Hz ± 0.08%

Voltage measurement/current measurement	Integration time	
	100µs to 10ms	1PLC to 200ms
	60dB	120dB

NMR: At AC 50/60 Hz ± 0.08%

Voltage measurement/current measurement	Integration time	
	100µs to 10ms	1PLC to 200ms
	0dB	60dB

Source and measurement function

DC source and measurement	Source and measurement of DC voltage and current
Pulse source and measurement	Source and measurement of pulse voltage and current (However, measurement auto range in pulse source is impossible)
DC sweep source and measurement	Source and measurement by Linear, Two slope linear, Random and Fixed levels
Pulse sweep source and measurement	Source and measurement by Linear, Two slope linear, Random and Fixed levels (However, measurement auto range in pulse source is impossible)
Integration time	9 types available: 100µs, 500µs, 1ms, 5ms, 10ms, 1PLC, 100ms, 200ms and S/H S/H: Sample hold (integration time: 100µs) measurement (Enabled only in the pulse source and pulse sweep source modes. PLC: Power Line Cycle 50Hz: 20ms 60Hz: 16.66ms
Sweep mode	Reverse ON (round) / OFF (one way)
Sweep repeat count	1 to 1000 times or infinite
Maximum number of sweep steps	8000 steps
Maximum random sweep memory	8000 data
Measurement data memory	8000 data
Measurement auto range	Available only in VSIM or ISVM
Measurement function link mode	Links the source function to the measurement function. (VSIM or ISVM) ON/OFF available
Limiter	The HI and LO limiters can be set individually. (However, current limiters of the same polarity are not allowed)
Calculation function	NULL calculation, comparator calculation (HI, GO, or LO) Scaling calculation MAX, MIN, AVE, TOTAL calculation
Trigger style	Auto trigger, External trigger
Output terminal	Front; Safety socket HI OUTPUT, HI SENSE, LO OUTPUT, and LO SENSE
Maximum input	6241A: 32V peak Max (between HI-LO) 2V peak Max (between OUTPUT and SENSE) 250V Max (between LO and chassis) 6242: 6V peak Max (between HI-LO)
Maximum remote sensing voltage	±1 V Max; HI OUTPUT - HI SENSE, LO OUTPUT - LO SENSE (The voltage between HI SENSE and LO SENSE must be within the maximum output voltage range)
Voltage measurement input resistance	1GΩ or higher
Voltage measurement input leak current	±1nA or lower
GPIB interface	Compliant with IEEE-488.1-1978 Interface function; SH1, AH1, T5, L4, SR1, RL1, PP0, DC1, DT1, C0, E2 Connector: Amphenol 24 pin
USB interface	USB 2.0 Full-speed Connector; Type B
External control signal	TRIGGER IN INTERLOCK/OPERATE IN/OPERATE OUT COMPLETE OUT/SYNC OUT Connector: BNC

Setting Time

Minimum pulse width: 50µs

Minimum step (repeat) time: Under fixed source/measurement range, integration time of 100µs, minimum measurement /source delay time, calculation function OFF, and voltage/current measurement

Measurement	Memory mode	Minimum step time
OFF	—	0.5ms
ON	BURST	2ms
	NORMAL	10ms
	OFF	

Source delay time:

Setting range	Resolution*6	Setting accuracy
0.030ms to 60.000ms	1µs	±(0.1% + 10µs)
60.01ms to 600.00ms	10µs	
600.1ms to 6000.0ms	100µs	
6001 ms to 59998 ms	1ms	

Period (pulse cycle):

Setting range	Resolution*6	Setting accuracy
0.500ms to 60.000ms	1µs	±(0.1% + 10µs)
60.01ms to 600.00ms	10µs	
600.1ms to 6000.0ms	100µs	
6001 ms to 60000 ms	1ms	

Pulse width:

Setting range	Resolution*6	Setting accuracy
0.050ms to 60.000ms	1µs	±(0.1% + 10µs)
60.01ms to 600.00ms	10µs	
600.1ms to 6000.0ms	100µs	
6001ms to 59998 ms	1ms	

Measurement delay time:

Setting range	Resolution*6	Setting accuracy
0.050ms to 60.000ms	1µs	±(0.1% + 10µs)
60.01ms to 600.00ms	10µs	
600.1ms to 6000.0ms	100µs	
6001ms to 59998 ms	1ms	

*6: The setting resolution is determined by the period time resolution.

Hold time:

Setting range	Resolution	Setting accuracy
1 ms to 60000 ms	1ms	±(2% + 3ms)

Auto range delay time:

Setting range	Resolution	Setting accuracy
0 ms to 500 ms	1ms	±(2% + 3ms)

General Specifications

Operating environment: Ambient temperature: 0°C to +50°C
Relative humidity: 85% or less, no condensation

Storage environment: Ambient temperature: -25°C to +70°C
Relative humidity: 85% or less, no condensation

Warm-up time: 60 minutes or more

Display: 16 segments x 12 digits vacuum fluorescent display

Power supply: AC power supply 100V/120V/220V/240V
(User selectable)

Option Number	Standard	OPT.32	OPT.42	OPT.44
Power supply voltage	100V	120V	220V	240V

Specify the option when ordering.
Use a power cable and a fuse that are compliant with the safety standard when changing the power supply voltage.

Line frequency: 50Hz/60Hz

Power consumption: 6241A: 95VA or less
6242: 180VA or less

Dimensions: Approx. 212 (W) x 88 (H) x 400 (D) mm

Mass: 6241A: 6kg or less
6242: 6.5kg or less

Safety: Compliant with IEC61010-1

EMI: EN61326 classA

Supplied Accessories

Name	Model	Quantity
Power cable	A01402	1
Input/output cable (safety plug)	A01044	1
Banana adapter (for A01044)	A08531	1

Optional Accessories

Name	Model
BNC-BNC cable (1.5m)	A01036-1500
Input cable (test probe)	A01041
Input/output cable (safety plug)	A01044
Input/output cable (large current, 0.5m)	A01047-01
Input/output cable (large current, 1m)	A01047-02
Input/output cable (large current, 1.5m)	A01047-03
Input/output cable (large current, 2m)	A01047-04
Test fixture	12701A
Banana adapter (for A01044)	A08531
Panel mount set	A02039
Panel mount set (twin)	A02040
JIS rack mount set	A02263
JIS rack mount set (twin)	A02264
EIA rack mount set	A02463
EIA rack mount set (twin)	A02464

- Please read through the operation manual carefully before using the products.
- All specifications are subject to change without notice.



ADC CORPORATION

E-mail : kcc@adcmt.com URL : <http://www.adcmt-e.com>

Head Office

Shoei Bldg, 3-6-12, Kyobashi, Chuo-ku,
Tokyo 104-0031, Japan
Phone: +81-3-6272-4433 Fax: +81-3-6272-4437

Higashimatsuyama Office (R&D Center)

77-1, Miyako Namegawa-machi, Hiki-gun,
Saitama 355-0812, Japan
Phone: +81-493-56-4433 Fax: +81-493-56-4281